

GalvinLab™ - CP-BS Lab Set 1-Way Type 16 Fixed J/V #16XT Tube Nozzle

Specification Data Sheet



Features

- Tough vandal resistant handle that have a unique locking system
- Quality controlled. Every tap is tested
- Comprehensive range of interchangeable nozzles including vandal resistant aerators, tube nozzles, fixed spray nozzles and 'XT' tube nozzle
- Replaceable top assemblies are supplied for easy maintenance
- High quality chrome finish for easy cleaning and hygiene maintenance
- Australian Made; therefore, spare parts and support are available locally, reducing costs of down time on maintenance

To Specify

Australian Made AS/NZS 3718 approved, Galvin Specialised GalvinLab™ school laboratory tapware is manufactured specifically to handle the knocks and hazardous chemicals present in a laboratory environment. Constructed from dezincification resistant (DR) brass the range comes standard in a bright chrome finish with jumper valves and vandal resistant handles.

Code:

TL16FJ16C – GalvinLab™ CP-BS Lab Set 1-Way Type 16 Fixed J/V #16 XT Tube Nozzle



A family
owned
Australian
business



galvinspecialised
commercial taps + fixtures

Performance Standards & Approvals

- AS/NZS 3718 – WaterMark
- WELS 5 Star Rating



Typical Dimensions

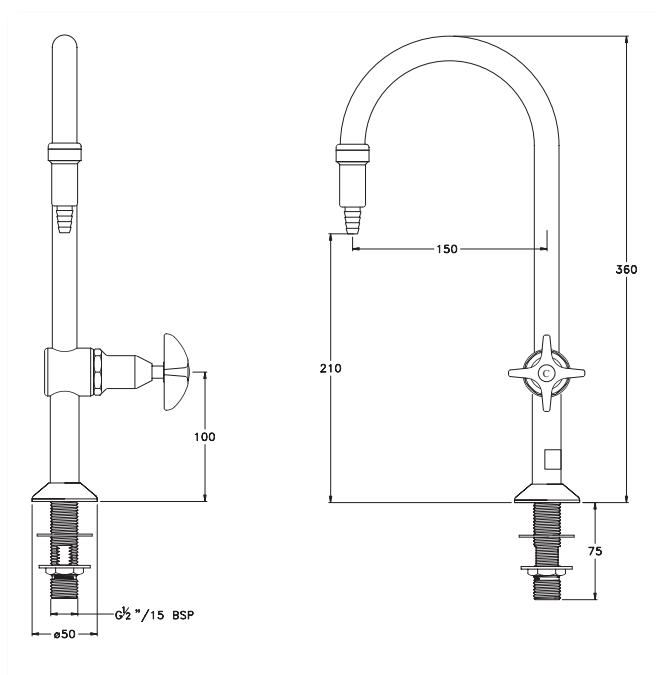

Technical Information

- Inlet: 1/2" BSP
- Outlet: XT Tube Nozzle
- Headwork: Jumper Valve
- Working Pressure Range (kPa): 50 Min - 500 Max
- Operating Temperature Range (°C): 5 Min - 80 Max
- Nominal Flow Rate (LPM): 5.6
- Finish: Chrome

Maintenance & Cleaning

Galvin Engineering products should be cleaned with a soft damp cloth using only mild liquid detergent or soap and water. Do not use cleaning agents containing a corrosive acid, scouring agent or solvents. Do not use cream cleaners, as they are abrasive. Use of unsuitable cleaning agents may damage the surface. Any damage caused in this way will not be covered by warranty.

Regular maintenance should be carried out in accordance with the installation and troubleshooting guides provided with the product, relevant Australian Standards, local authorities and state codes.

As part of maintaining a safe and reliable plumbing system, we recommend tapware and valves are operated on at least a daily basis.

Warranty

Galvin Engineering products are covered under our Manufacturer's Warranty at www.galvinengineering.com.au. Galvin Engineering products must be installed in accordance with the installation instructions and in accordance with AS3500 and the PCA, relevant Australian Standards and local authorities applicable to product being installed. Water and electrical supply conditions must also comply to the applicable national and/or state standards, failing to comply with these provisions may void the product warranty and affect performance of the product.

Whilst all reasonable care has been taken in compiling the information in this document, the designs, dimensions and products shown are indicative only and should not be relied upon without our prior approval. Due to our policy of continuous development, we reserve the right to alter any details of specifications or products without notice. All information, drawings, technical specifications and product designs remains the property of Galvin Engineering Pty Ltd.

Within Australia: **1300 514 074** Outside Australia: P: +61 (0)8 9338 2344
 F: +61 (0)8 9338 2340
sales@galvinengineering.com.au
www.galvinengineering.com.au
 ABN: 78 008 719 382

A business unit of

GalvinEngineering
 the mark of reliability



PERTH | SYDNEY | MELBOURNE | BRISBANE | ADELAIDE | UNITED STATES OF AMERICA | UNITED KINGDOM | NEW ZEALAND